



50mA Regulated Step-Down Charge Pump for 1.8V or 1.9V Logic

MAX1730

General Description

The MAX1730 regulated step-down charge pump generates up to 50mA at fixed output voltages of 1.8V or 1.9V from an input voltage in the 2.7V to 5.5V range. Specifically designed to provide high-efficiency logic supplies in applications that demand a compact design, the MAX1730 employs fractional conversion techniques to provide efficiency exceeding that of a linear regulator.

The MAX1730 operates at up to 2MHz, permitting the use of small 0.22 μ F flying capacitors while maintaining low 75 μ A quiescent supply current. Proprietary soft-start circuitry prevents excessive current from being drawn from the supply during startup, making the MAX1730 compatible with higher impedance sources such as alkaline and lithium-ion cells.

The MAX1730 is available in a space-saving 10-pin μ MAX package that is only 1.09mm high and occupies one-half the area of an 8-pin SO.

Applications

Low-Voltage Logic Supplies
Wireless Handsets
PDAs
PC Cards
Hand-Held Instruments

Typical Operating Circuit

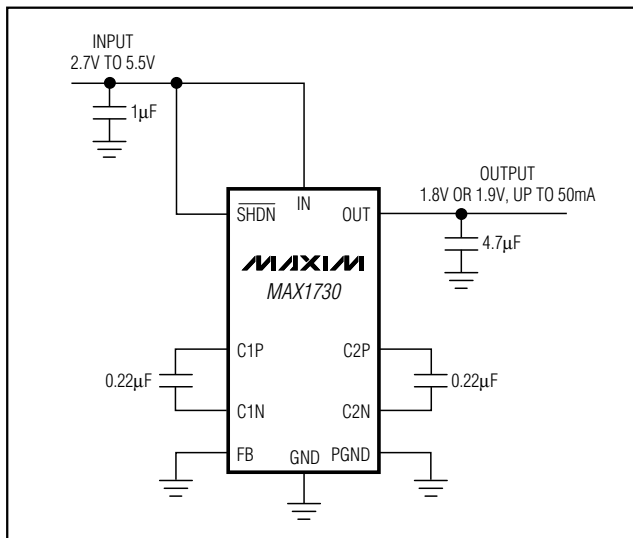

Features

- ◆ > 85% Peak Efficiency
- ◆ 50mA Guaranteed Output Current
- ◆ Dual-Mode 1.8V or 1.9V Output
- ◆ \pm 3% Output Voltage Accuracy
- ◆ Up to 2MHz Operating Frequency
- ◆ Small 0.22 μ F Capacitors
- ◆ No Inductor Required
- ◆ 2.7V to 5.5V Input Voltage Range
- ◆ Output Disconnects from Input in Shutdown Mode
- ◆ Small 10-Pin μ MAX Package (1.09mm max height)

Ordering Information

PART	TEMP. RANGE	PIN-PACKAGE
MAX1730EUB	-40°C to +85°C	10 μ MAX

Pin Configuration

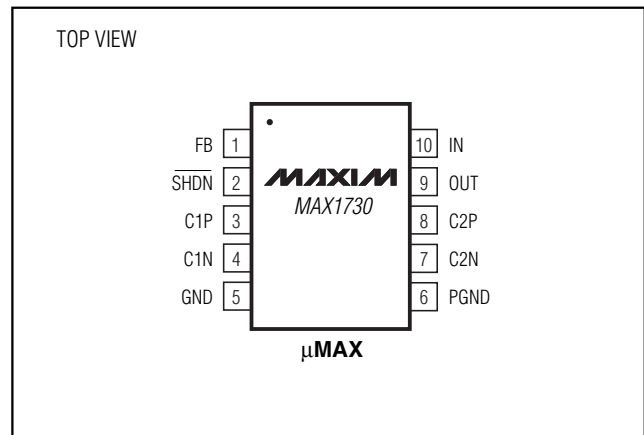

50mA Regulated Step-Down Charge Pump for 1.8V or 1.9V Logic

ABSOLUTE MAXIMUM RATINGS

IN, OUT, $\overline{\text{SHDN}}$, FB to GND-0.3V to +6V
 C1P, C1N, C2P, C2N to GND-0.3V to ($V_{\text{IN}} + 0.3\text{V}$)
 GND to PGND $\pm 0.3\text{V}$
 Output Short-Circuit DurationIndefinite
 Continuous Power Dissipation ($T_{\text{A}} = +70^{\circ}\text{C}$)
 10-Pin μMAX (derate 5.6mW/ $^{\circ}\text{C}$ above +70 $^{\circ}\text{C}$)444mW

Junction Temperature+150 $^{\circ}\text{C}$
 Operating Temperature Range-40 $^{\circ}\text{C}$ to +85 $^{\circ}\text{C}$
 Storage Temperature Range-65 $^{\circ}\text{C}$ to +150 $^{\circ}\text{C}$
 Lead Temperature Range (soldering, 10s).....+300 $^{\circ}\text{C}$

Stresses beyond those listed under "Absolute Maximum Ratings" may cause permanent damage to the device. These are stress ratings only, and functional operation of the device at these or any other conditions beyond those indicated in the operational sections of the specifications is not implied. Exposure to absolute maximum rating conditions for extended periods may affect device reliability.

ELECTRICAL CHARACTERISTICS

($V_{\text{IN}} = +3.6\text{V}$, FB = GND, $\overline{\text{SHDN}} = \text{IN}$, $T_{\text{A}} = 0^{\circ}\text{C}$ to +85 $^{\circ}\text{C}$, unless otherwise noted. Typical values are at $T_{\text{A}} = +25^{\circ}\text{C}$.)

PARAMETER	SYMBOL	CONDITIONS		MIN	TYP	MAX	UNITS
Input Voltage Range	V_{IN}			2.7		5.5	V
Input Undervoltage Lockout		Falling edge (100mV hysteresis)		2.3		2.6	V
Output Voltage	V_{OUT}	$V_{\text{IN}} = 2.7\text{V}$ to 5.5V, $I_{\text{OUT}} = 0$ to 50mA	FB = GND	1.746	1.80	1.854	V
			FB = IN	1.843	1.90	1.957	
Output Leakage Current		OUT forced to 1.8V, $V_{\text{IN}} = 1.8\text{V}$ to 5.5V, $\overline{\text{SHDN}} = \text{GND}$			1	5	μA
No-Load Supply Current		$\overline{\text{SHDN}} = \text{IN}$			75	150	μA
Shutdown Supply Current		$V_{\text{IN}} = 4.2\text{V}$, $\overline{\text{SHDN}} = \text{GND}$, $V_{\text{OUT}} = 1.8\text{V}$ or GND			1	5	μA
Output Short-Circuit Current		$V_{\text{OUT}} = \text{GND}$			45	125	mA
Oscillator Frequency				1.5	2.0	2.5	MHz
Thermal Shutdown Threshold					150		$^{\circ}\text{C}$
Thermal Shutdown Threshold Hysteresis					15		$^{\circ}\text{C}$
V_{IN} Transition Voltage (V_{IN} Rising)		FB = GND	From 1:1 to 2:3	3.1	3.2	3.35	V
			From 2:3 to 1:2	4.00	4.12	4.30	
Startup Timer					4.1		ms
$\overline{\text{SHDN}}$ Logic Input High Voltage	V_{IH}	$V_{\text{IN}} = 2.7\text{V}$ to 5.5V		1.4			V
$\overline{\text{SHDN}}$ Logic Input Low Voltage	V_{IL}	$V_{\text{IN}} = 2.7\text{V}$ to 5.5V				0.6	V
Shutdown Logic Input Current	$I_{\overline{\text{SHDN}}}$	$\overline{\text{SHDN}} = \text{IN}$ or GND		-1		1	μA

50mA Regulated Step-Down Charge Pump for 1.8V or 1.9V Logic

MAX1730

ELECTRICAL CHARACTERISTICS

($V_{IN} = +3.6V$, $FB = GND$, $\overline{SHDN} = IN$, $T_A = -40^{\circ}C$ to $+85^{\circ}C$, unless otherwise noted.) (Note 1)

PARAMETER	SYMBOL	CONDITIONS	MIN	MAX	UNITS	
Input Voltage Range	V_{IN}		2.7	5.5	V	
Input Undervoltage Lockout		Falling edge (100mV hysteresis)	2.3	2.6	V	
Output Voltage	V_{OUT}	$V_{IN} = 2.7V$ to $5.5V$, $I_{OUT} = 0$ to $50mA$	FB = GND	1.746	1.854	V
			FB = IN	1.843	1.957	
Output Leakage Current		OUT forced to 1.8V, $V_{IN} = 1.8V$ to $5.5V$, $\overline{SHDN} = GND$		5	μA	
No-Load Supply Current		$\overline{SHDN} = IN$		150	μA	
Shutdown Supply Current		$V_{IN} = 4.2V$, $\overline{SHDN} = GND$		5	μA	
Output Short-Circuit Current		$V_{OUT} = GND$		125	mA	
Oscillator Frequency	f		1.5	2.5	MHz	
V_{IN} Transition Voltage (V_{IN} Rising)		FB = GND	From 1:1 to 2:3	3.1	3.35	V
			From 2:3 to 1:2	4.00	4.30	
\overline{SHDN} Logic Input High Voltage	V_{IH}	$V_{IN} = 2.7V$ to $5.5V$	1.4		V	
\overline{SHDN} Logic Input Low Voltage	V_{IL}	$V_{IN} = 2.7V$ to $5.5V$		0.6	V	
Shutdown Logic Input Current	$I_{\overline{SHDN}}$	$\overline{SHDN} = IN$ or GND	-1	1	μA	

Note 1: Specifications to $-40^{\circ}C$ are guaranteed by design, not production tested.

50mA Regulated Step-Down Charge Pump for 1.8V or 1.9V Logic

Typical Operating Characteristics

($V_{IN} = +3.6V$, $FB = GND$, $\overline{SHDN} = IN$, $C_{IN} = 1\mu F$, $C_1 = C_2 = 0.22\mu F$, $C_{OUT} = 4.7\mu F$, $T_A = +25^\circ C$, unless otherwise noted.)

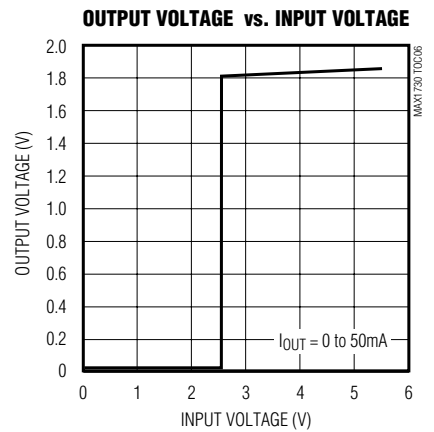
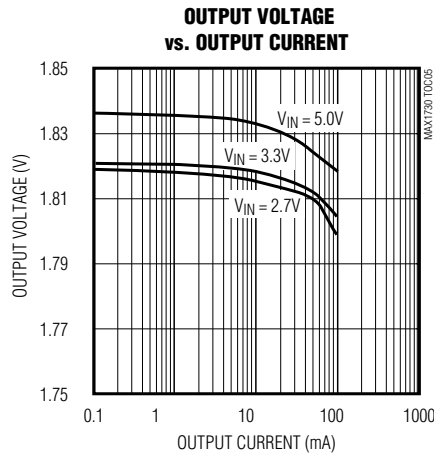
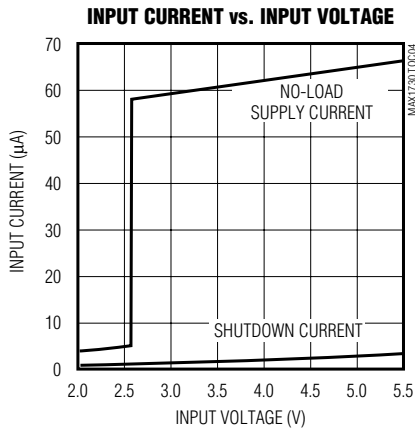
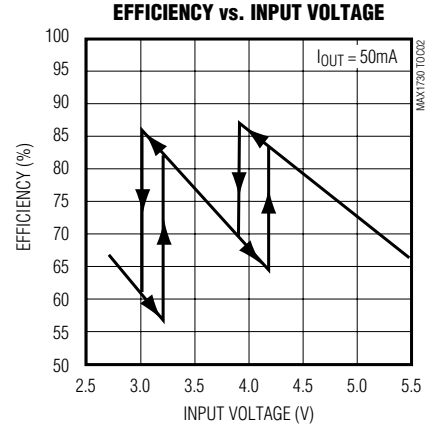
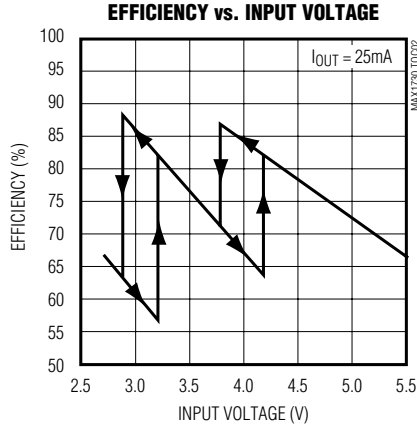
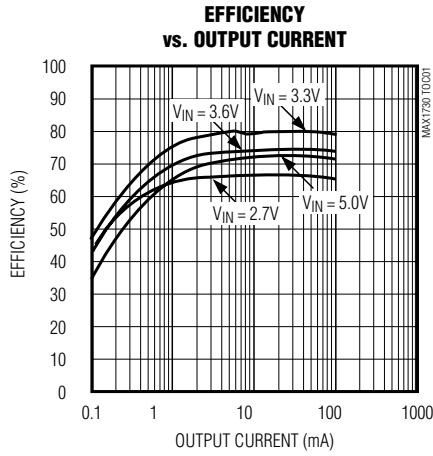

50mA Regulated Step-Down Charge Pump for 1.8V or 1.9V Logic

MAX1730

Typical Operating Characteristics (continued)

($V_{IN} = +3.6V$, $FB = GND$, $\overline{SHDN} = IN$, $C_{IN} = 1\mu F$, $C_1 = C_2 = 0.22\mu F$, $C_{OUT} = 4.7\mu F$, $T_A = +25^\circ C$, unless otherwise noted.)

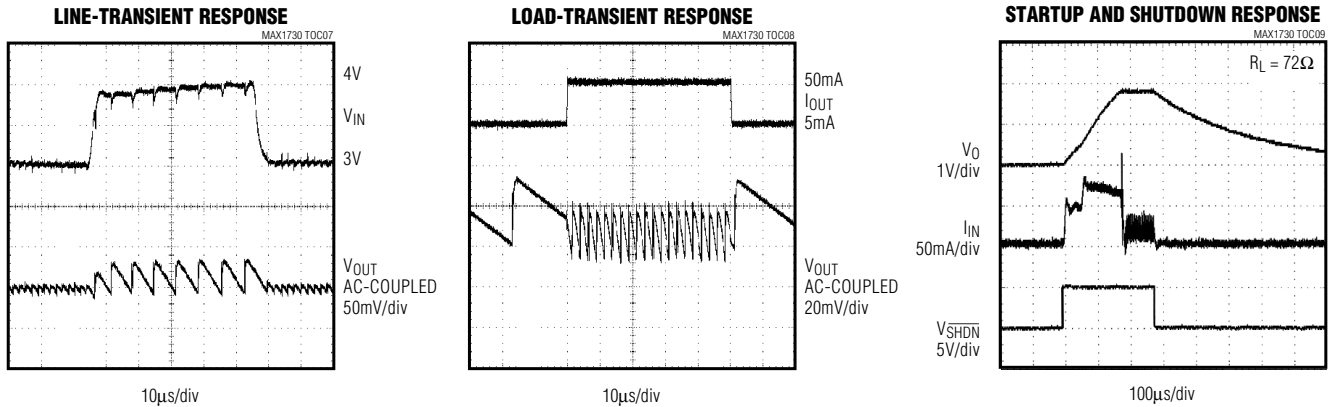

Pin Description

PIN	NAME	FUNCTION
1	FB	Feedback Input. Connect FB to GND for a 1.8V output. Connect FB to IN for a 1.9V output. Do not leave FB unconnected.
2	\overline{SHDN}	Active-Low Shutdown Input. Connect to logic control or to IN for normal operation. OUT disconnects from the input in shutdown and goes to high impedance.
3	C1P	C1 Flying Capacitor Positive Connection
4	C1N	C1 Flying Capacitor Negative Connection
5	GND	Ground
6	PGND	Power Ground
7	C2N	C2 Flying Capacitor Negative Connection
8	C2P	C2 Flying Capacitor Positive Connection
9	OUT	Output. Bypass to GND with a 4.7μF or greater capacitor.
10	IN	Input Supply. Connect to a +2.7V to +5.5V supply. Bypass to GND with a 1μF ceramic capacitor as close to the IC as possible.

50mA Regulated Step-Down Charge Pump for 1.8V or 1.9V Logic

Functional Diagram

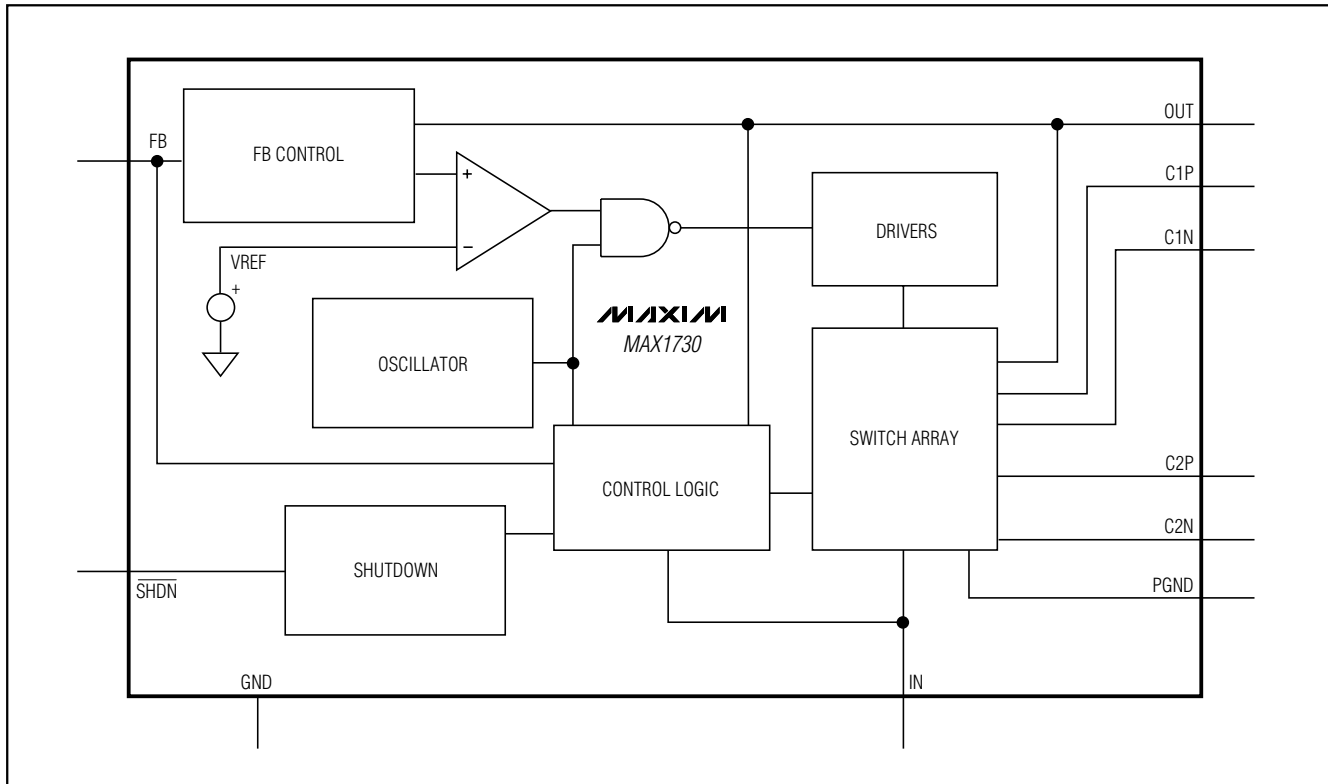

Detailed Description

The MAX1730 step-down charge pump automatically switches between charge pump configurations (Figures 1, 2, and 3) and utilizes pulse-skipping pulse-frequency modulation (PFM) to provide a regulated output voltage with high efficiency. The output voltage is pin-selectable to 1.8V or 1.9V. The MAX1730 accepts inputs between 2.7V and 5.5V and guarantees up to 50mA output current.

Charge-Pump Configurations

Charge pumps work by passing energy through capacitors. They generally work in two phases. In the first phase, the input source charges the flying capacitors. The input capacitor helps reduce the source's input impedance. In the second phase, the switching capacitors transfer their charge to the output as needed.

Figure 1 shows the 1:1 charge-pump configuration. C1 and C2 charge in parallel between IN and GND during the first phase. In the second phase, C1 and C2 connect in parallel between OUT and GND.

Figure 2 shows the 3:2 charge-pump configuration. C1 and C2 charge in parallel between IN and OUT during the first phase. In the second phase, C1 and C2 connect in series between OUT and GND.

Figure 3 shows the 2:1 charge-pump configuration. C1 and C2 charge in parallel between IN and OUT during the first phase. In the second phase, C1 and C2 connect in parallel between OUT and GND.

Pulse-Skipping PFM and Mode Transitions

In the MAX1730, pulse-skipping PFM mode pauses the oscillator when the output is in regulation. Using the 2:1 charge-pump configuration as an example, when the output is set to half the input, the switching frequency is near the oscillator frequency. However, for outputs below half the input, switching pauses once the desired output level is achieved. With no output current, the device switches occasionally. With higher levels of current, the switching frequency increases to supply the load.

50mA Regulated Step-Down Charge Pump for 1.8V or 1.9V Logic

MAX1730

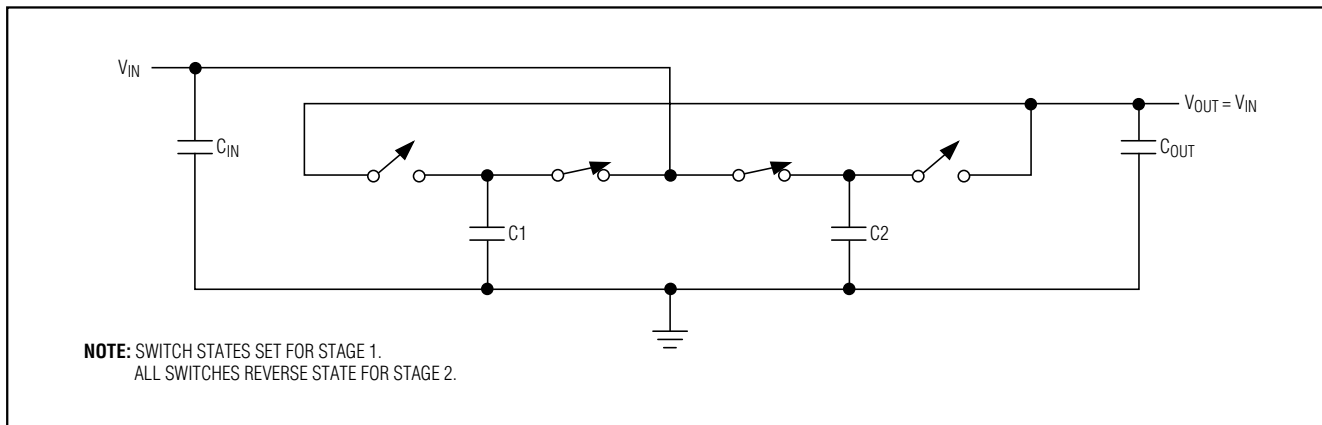

Figure 1. 1:1 Capacitor Configuration

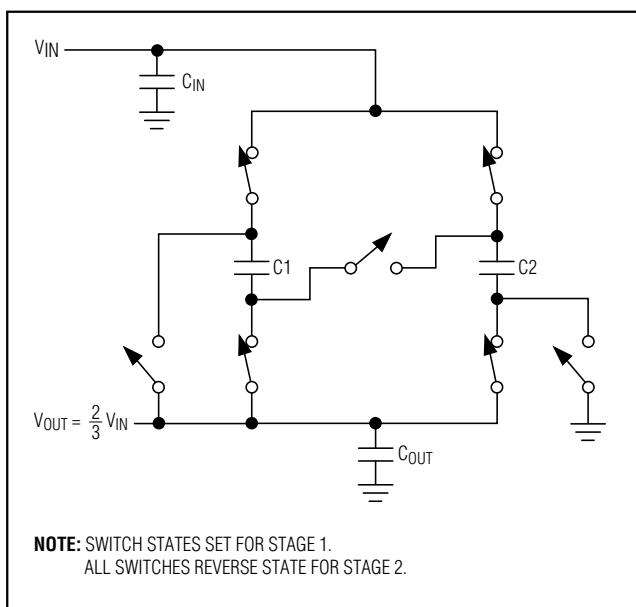

Figure 2. 3:2 Capacitor Configuration

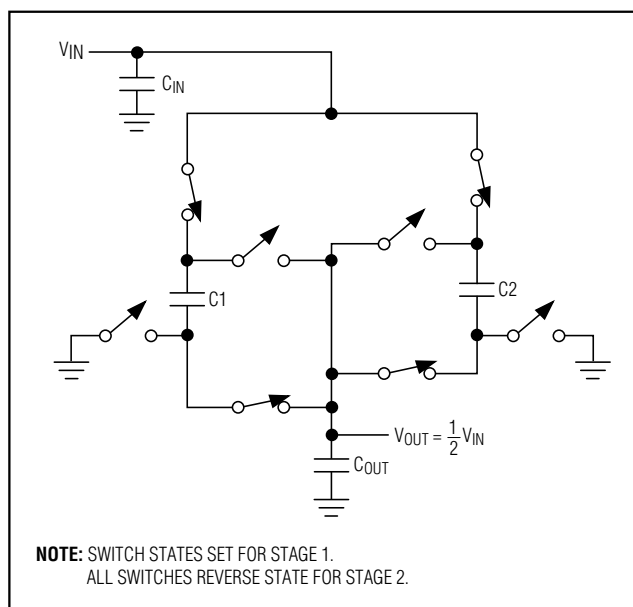

Figure 3. 2:1 Capacitor Configuration

To maximize efficiency, the MAX1730 automatically switches between charge-pump configurations (Figures 1, 2, and 3). Efficiency is greatest when the IN/OUT voltage ratio is close to the voltage ratio of the selected capacitor configuration and decreases for output voltages lower than the divider ratio. To choose between configurations, the MAX1730 senses the input voltage and the output voltage. The MAX1730 uses a control scheme with hysteresis to prevent oscillation between capacitor configurations.

Applications Information

Setting the Output Voltage

For an output voltage of 1.8V, connect FB to GND. For an output voltage of 1.9V, connect FB to IN.

50mA Regulated Step-Down Charge Pump for 1.8V or 1.9V Logic

Shutdown

The MAX1730 features an active-low shutdown pin (SHDN) to decrease supply current to below 5 μ A. When in shutdown, the output disconnects from the input and OUT goes to high impedance.

Capacitor Selection

The input capacitor provides the charge pump with a low-impedance supply. For most applications, a 1 μ F ceramic capacitor is adequate. Lower-value capacitors and those with higher ESR may be inadequate for proper operation and may result in lower output current capability and higher output ripple.

To reduce the output voltage ripple, the value of the output capacitor should exceed that of the flying capacitors (C1 + C2) by 10:1 or more. Values for C1 and C2 between 0.22 μ F and 0.47 μ F are recommended for most applications. Use ceramic capacitors to increase maximum output current and improve efficiency.

Layout Considerations

The MAX1730's high-frequency operation demands careful layout. All components should be placed as close to the IC as possible, with priority going to CIN, C1, and C2. Traces should be kept short, wide, and as straight as possible. Connect PGND and GND together with a low-impedance ground plane.

Chip Information

TRANSISTOR COUNT: 2295

Package Information

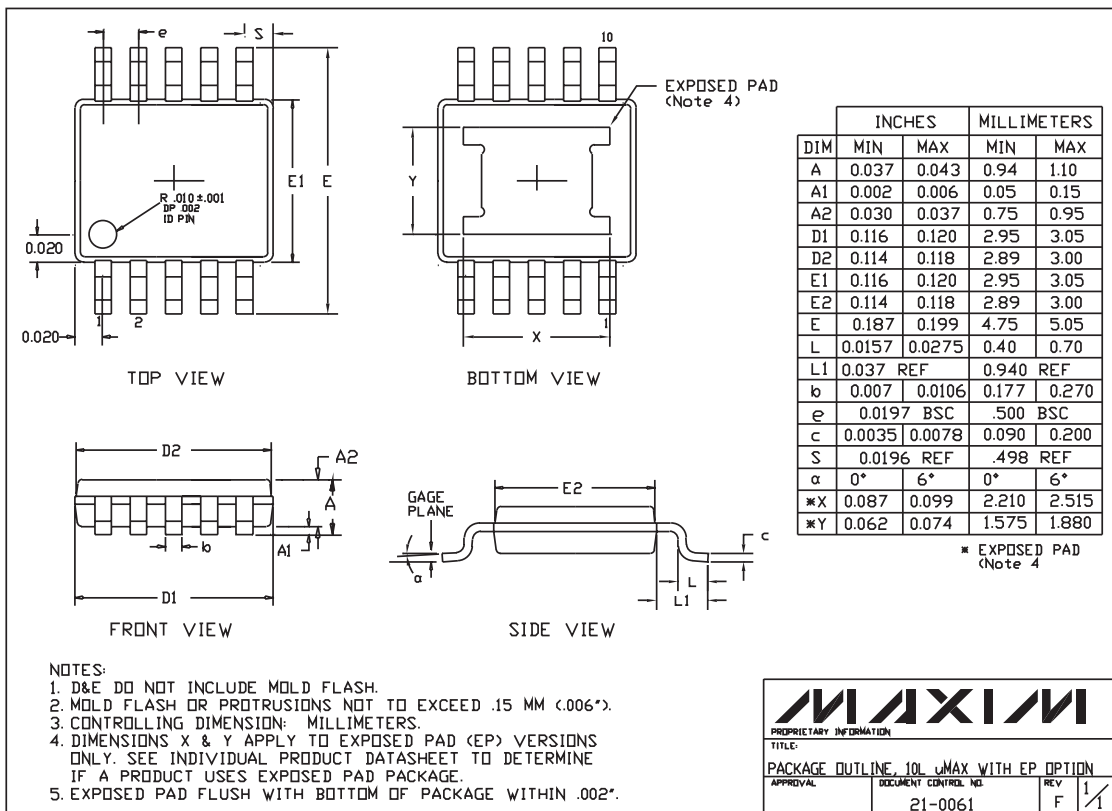

Note: The MAX1730 does not have an exposed pad.

Maxim cannot assume responsibility for use of any circuitry other than circuitry entirely embodied in a Maxim product. No circuit patent licenses are implied. Maxim reserves the right to change the circuitry and specifications without notice at any time.

8 **Maxim Integrated Products, 120 San Gabriel Drive, Sunnyvale, CA 94086 408-737-7600**